

Horizontal Hot Plate Welder

Heated Platen Size 13" (330mm) by 24" (610mm)



FEATURES

- Rugged welded steel tube frame
- All-pneumatic operation
- Unique Rack System coordinates tool platen motion
- Single power air cylinder for reduced machine complexity
- Two temperature zones standard – Field upgradeable to four zones
- Touch screen interface with all digital timing
- Controls mounted on space saving pendant arm
- Manual-close auto-open door
- Door closure initiates cycle
- Fully adjustable hot plate carrier
- Fully enclosed cabinet with exhaust fans
- Interior work light
- Numerous large access doors with keyed hardware
- Pneumatic system in lockable cabinet
- Separate pressure controls for melt and seal
- Vacuum part retention system

SPECIFICATIONS

- Maximum heated platen size: 13" x 24" (330 x 610mm)*
- Minimum tool shut height 12" (305mm), with hot plate retracted
- Maximum tool shut height 25" (635mm), with part in place and hot plate extended
- Maximum clamp force 1250 lbs. (5560N)

OPTIONS

- Expand from two temperature zones to four
- Light curtain with auto close door and single zero force cycle initiate switch
- Part clamping or Part-in-Place sensing
- Customer specified PLC and interface
- Custom paint per customer specification
- Hydraulic system
- Custom contoured hot plate carrier
- We can also quote custom machines in vertical and horizontal configurations, either pneumatic or hydraulic

*Tooling that is larger in front-to-back dimensions can be often be accommodated. Consult Dukane for more information

Hot Plate Welder Model HHB1223P Floor Layout

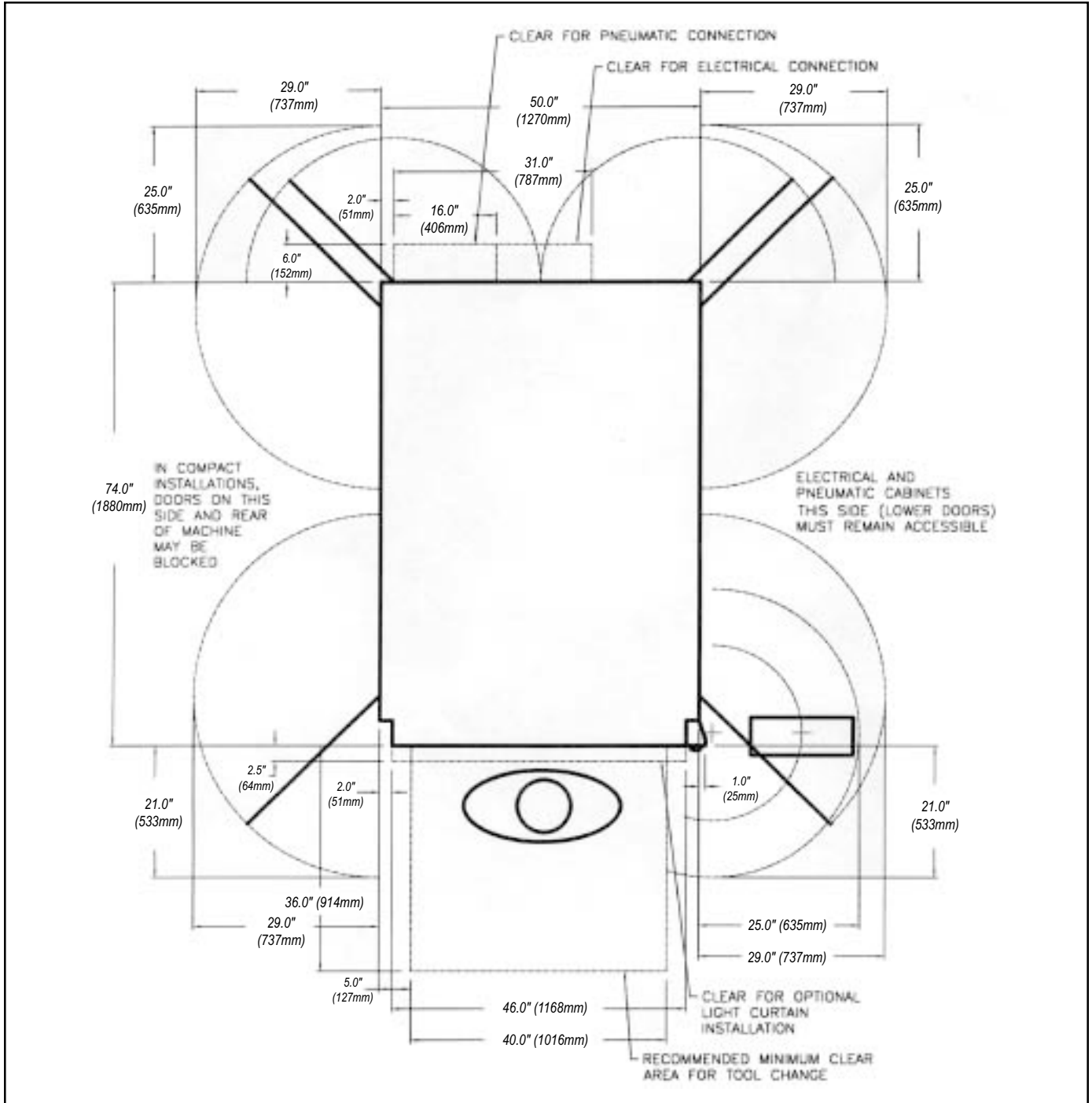

Note: All specifications are subject to change without notice. Please consult Dukane Ultrasonics for any updated information.

Electric Service Required: 240V, 3 Phase, 20 Amps

Pneumatic Service Required: 75 to 90PSI (5-6 Bar)